

- 1 A stream restoration project is planned for a sand bed channel that is currently straight and extremely wide due to historic channelization and straightening. The channel will be narrowed by 30 percent. Given the following data, determine the contraction scour depth for clear-water and Live-bed conditions and recommend the appropriate value.

$$S = 0.0008 \quad ; \quad n = 0.034 \quad ; \quad d_{50} = 0.3 \text{ mm} \quad ; \quad Q = 390 \text{ m}^3/\text{s}$$

$$y_0 = 3.0 \text{ m} \quad ; \quad W = 70 \text{ m} \quad ; \quad V = 2.2 \text{ m/s}$$

- 2 During the design of a bridge, several complex pier configurations were tested in physical model studies. The purpose of this problem is to analyze local scour for the cylindrical pier configured as shown in the figure. It was determined that the water velocity would be 3.0 m/s for the  $Q_{100}$ . Determine the local scour using the superposition method and the effective diameter method. Use plane bed condition and  $d_{50} = 0.7 \text{ mm}$ .

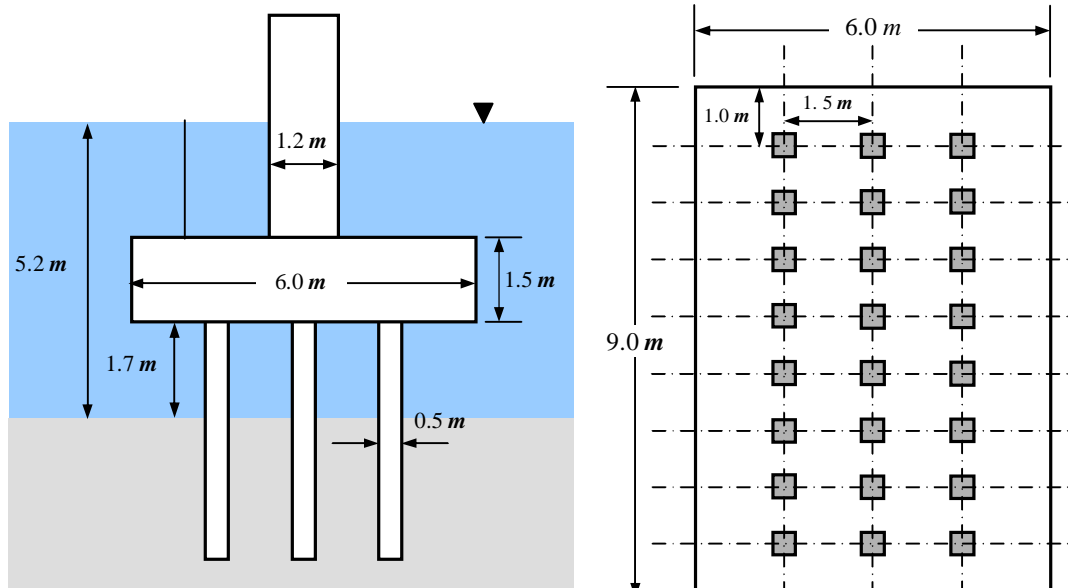

Elevation View

Plan View

